

Before you begin to assemble your new piece of furniture please check to ensure all parts and fittings have been supplied. Follow all instructions closely as deviation from them may void warranty and present possible safety risk. It is recommended that assembly is done on a soft surface, like carpet, to avoid damage. CARE INSTRUCTIONS: Periodically re-tighten all fasteners. TOOLS REQUIRED: Allen key (provided), screwdriver and hammer. Some packs may come with timber of a different colour to the model purchased. These pieces are for packing purposes only.

If you experience any problems with your new purchase please phone our Customer Service staff on (FREE CALL PHONE / FAX) 1800 029 715

Please keep last page of the instruction for warranty information.





CLEANING AND MAINTENANCE: Do not use solvent or alcohol based cleaners on this unit. To clean unit, we recommend using a warm damp cloth to wipe over surfaces.

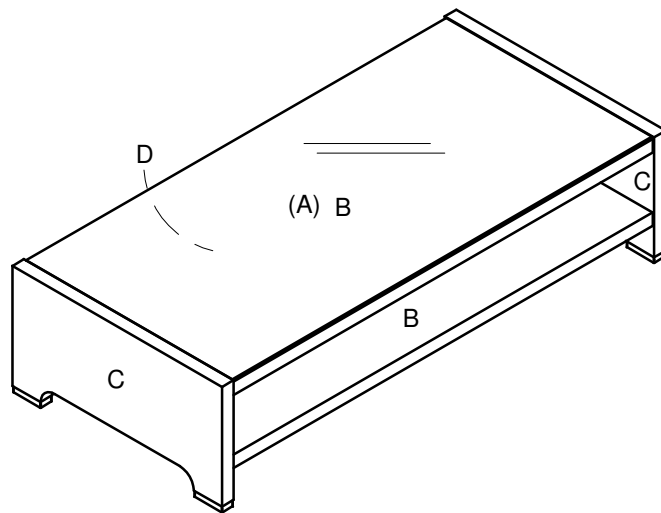



PARTS CHECKLIST

CODE	PART	SIZE	QTY
A	GLASS TOP	1193 x 585	1
B	TOP / SHELF	1195 x 587	2
C	SIDE	295 x 595	2
D	RAIL	1195 x 80	1





FITTINGS CHECKLIST

CODE	FITTING	DESCRIPTION	QTY
50-001		32mm WOODEN DOWEL	10
50-009		4mm ALLEN KEY	1
50-015		METAL DOWEL	10
50-016		METAL CAM	10
50-043		HI LO SCREW	8

CODE	FITTING	DESCRIPTION	QTY
50-140		METAL CAM COVER	2
50-459		BUMP STOP	6
51-511		METAL FOOT	4
80-001		GLUE	1

STEP 1: PREPARE SIDES (x 2)



 50-015
x 10

 50-043
x 8

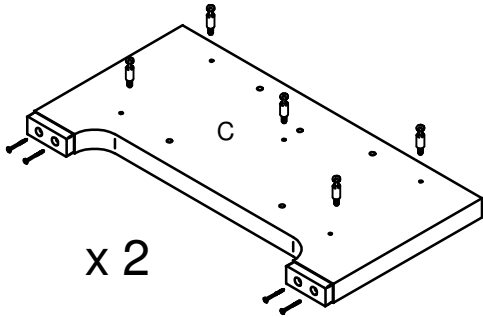
 51-511
x 4



STEP 2: PREPARE RAIL

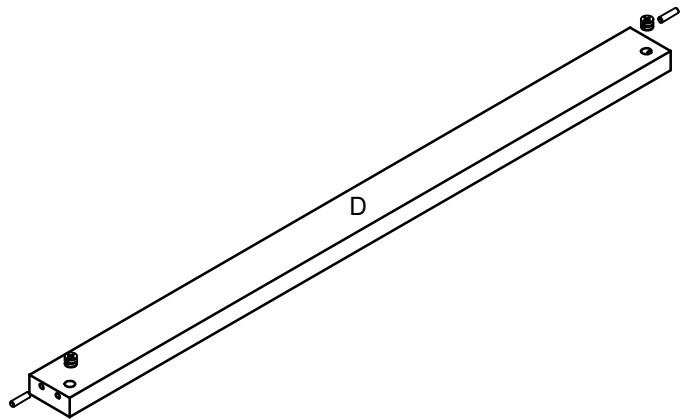

 50-001
x 2 

 50-015
x 2



STEP 3: PREPARE TOP AND SHELF

 50-015
x 8

 50-001
x 8 

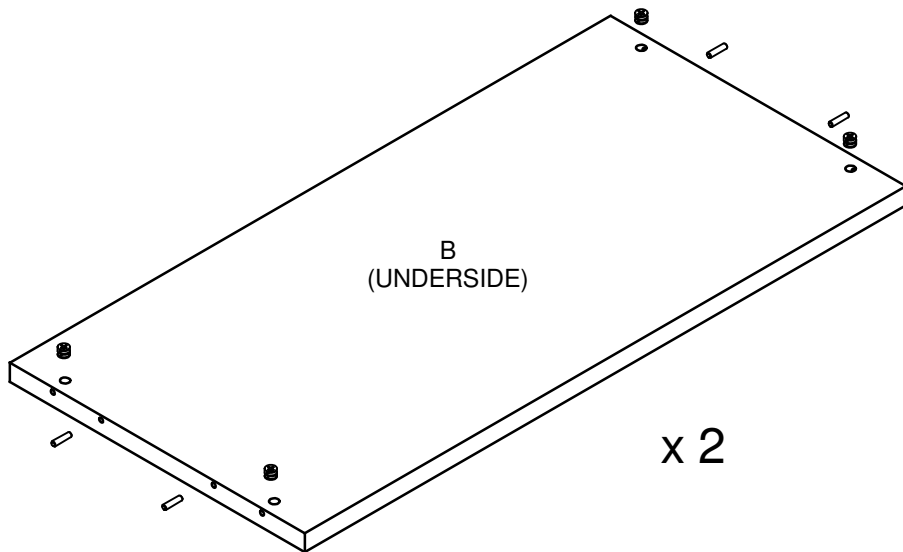

STEP 4: POSITION AND LOCK TO, SHELF AND RAIL

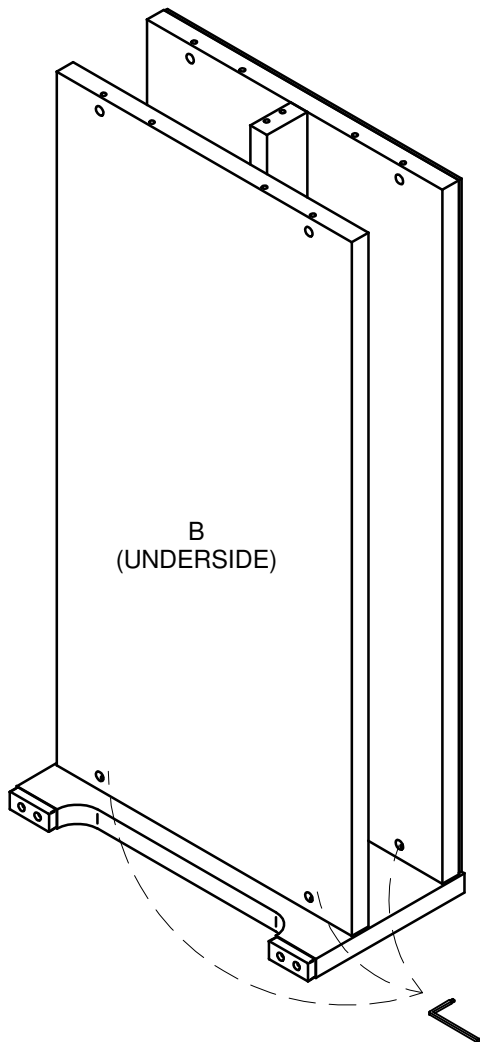
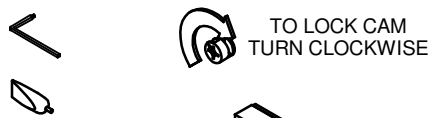

STEP 5: POSITION AND LOCK OTHERSIDE

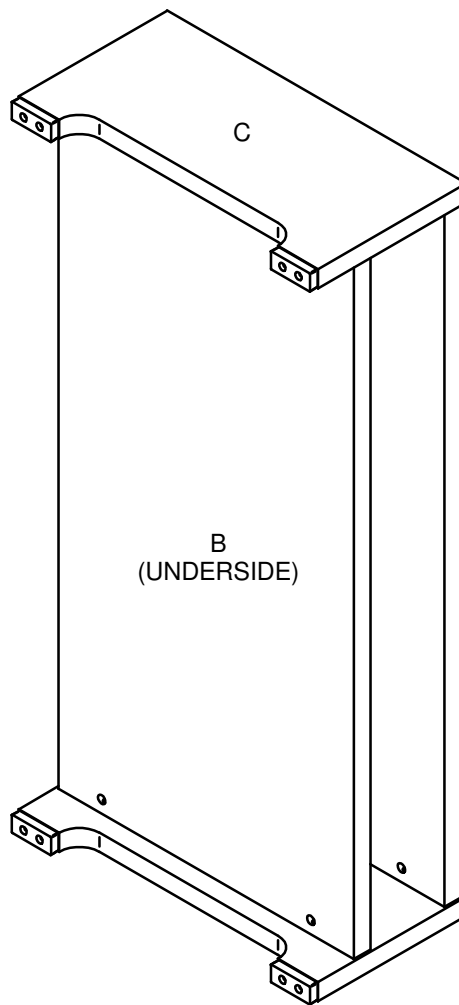

STEP 6: POSITION GLASS

